



Rubinerterre Italiane Velatta SpA
————— since 1950 —————

>> **YOU need the BEST**

opale
Series



RIV 230

Spring operated pressure relief valve with free discharge

» Tech Drawings And Tables

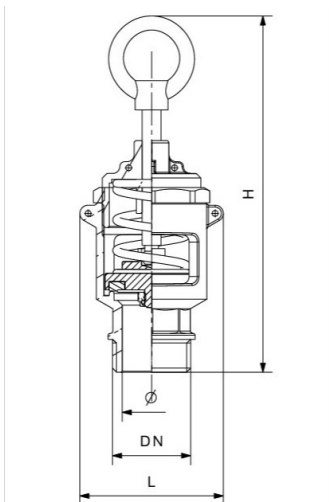

DN	Code	Ø	H	L	PN	KG	P/box
1"	050230000007	25	152	61	1,5bar - 21psi	0,454	30
1"1/2	050230000009	39	156	66	1,5bar - 21psi	0,760	15
2"	050230000011	51	160	77	1,5bar - 21psi	1,095	10

»» Advantages

Environmentally compatible, thanks to its hose-connection, where you can apply a pipe for discharging any possible polluting leakages into a proper tank. The valve can be easily adjusted to the desired pressure (from 0,5 to 1,5 bar - from 7 to 21 psi) and it can be sealed tamper-proof through the drilled tongues.

Certified in accordance with 2014/68/UE (PED).

»» Certifications



>> Tech Data

RIV 250

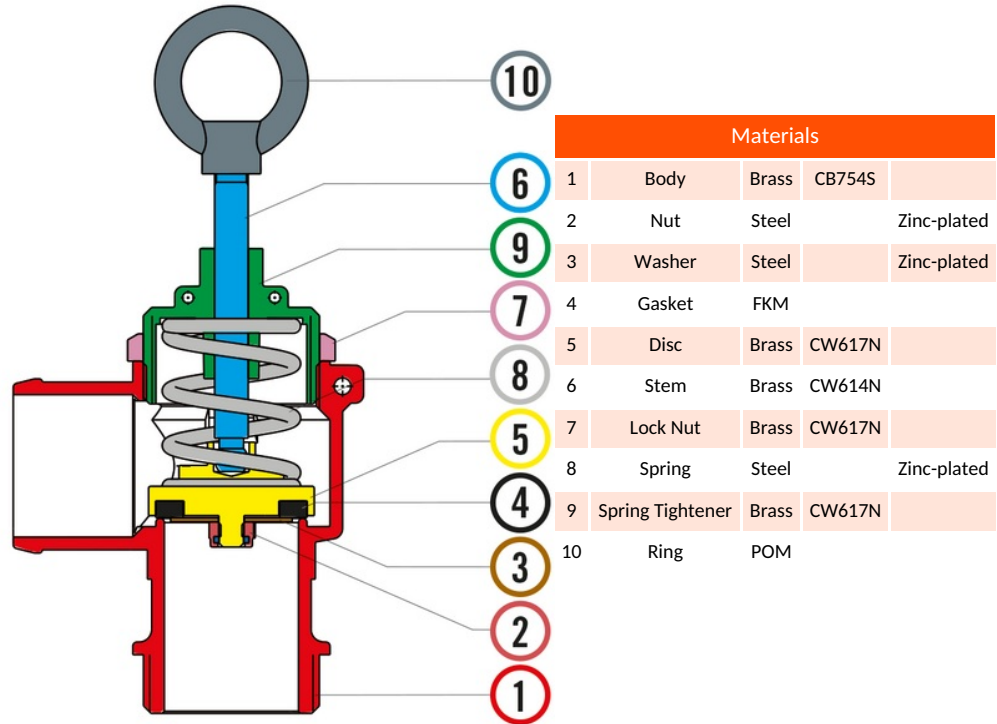

Info Junction	ISO 228/1, ANSI B1.20.1 (NPT)
Info Limits	-20°C (-4°F) (without liquid) +180°C (+356°F)
Info Notes	<p>The max.working pressure (PN) means at a room temperature of about 23°C.</p> <ul style="list-style-type: none"> • Pressure relief valve intended for exclusive use on the slurry tanker, at a max. 1.5 bar (21 psi). • The valve is intended for the discharge of gaseous fluids, it's not suitable for the passage of liquids especially if with solid part in suspension (Slurry, etc.) • The valve doesn't replace the 4th category safety device which must in any case be present on the system.



» Other Products



RIV 250

Spring operated pressure relief valve
with hose-connection

» RIV 90250 Calibrated & sealed



RIV 251

Spring operated pressure relief valve
with hose-connection
NPT thread